



LED LIGHT SHEETS/DESIGN – MANUFACTURE – ILLUMINATE PROJECTS

EXQUISITE BRAND IMAGE

Lumaire Textile



EXQUISITE BRAND IMAGE

Lumaire Textile



- Frame thickness is just 23 mm single sided
- Brightness up to 11000 lx on the surface depending on the size
- Single and double sided
- Low power consumption
- Wide application possibilities, from interior design to signage

Luminous Textile panels is a choice of luxury. The exceptional design leaves no doubt that luminous textile is the best for an exquisite image and brand lighting. Lumaire Textile LED sheet panel frames your desired image, the patent acrylic formula ensures twice higher light scattering coefficient.

SUPPORT 24/7, PROTECTION & WARRANTY



1.



2.



3.



4.

VARIATIONS

1. Textile one-sided

One-sided LED Lumaire Textile panels emit light with the front surface. By choosing a one-sided design, you will enjoy high-quality elegance and a thin 23 mm thick panel.

2. Textile two-sided

Two-sided Lumaire Textile emits light with its whole surface. Use 2x more chances to stand out. The diffuser in the luminous textile panels makes the image visible from both sides. Two-sided LED panel is 50 mm thick.

3. Textile two-point cable fixation

One of the Lumaire Textile installation options is cable fixation.

4. Textile installation options

Lumaire Textile installation can either be portable or stationary. With the mobile stand, the LED light sheet can be moved from one place to another. Other fixation includes cables or screw mounting. Textile panels on a stand are available in sizes up to 1 800 cm high and 100 cm width.

TECHNICAL SPECIFICATIONS

Main material	Led Strip Power	Maximum size	Lifetime	Operating temperature	Color Temperature
Clear acrylic (PMMA)	15W/M	5000 x 1250 mm	> 50,000 hours	-30°C ~ + 40°C	 3000 K  4000 K  5000 K  6500 K  CCT (Special order)  RGB (Special order)
IP RATING	Luminous efficiency	Power supply	Working voltage	Input voltage	
IP 20	up to 160lm/W	DC 12V / 24V / CC Adaptor	DC 12V / DC 24V / CC	AC 100 ~ 240V 50/60Hz	

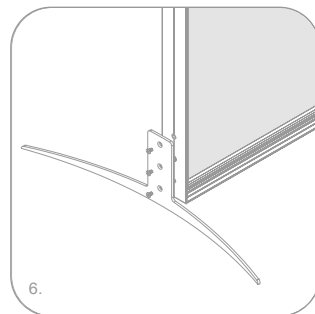
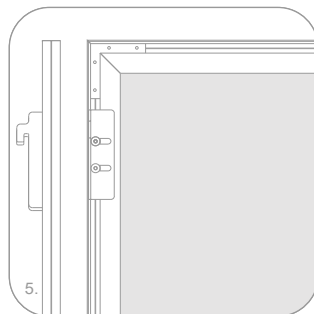
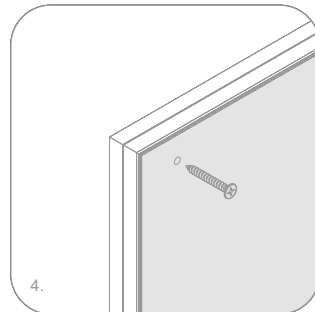
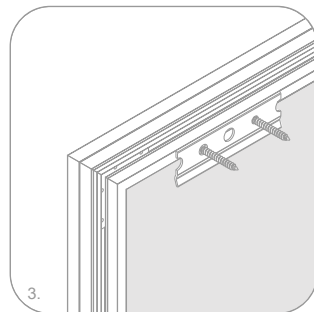
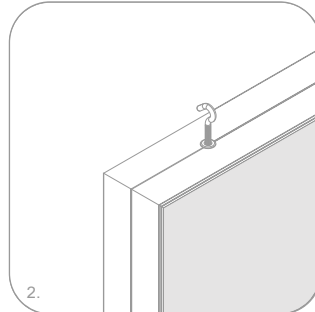
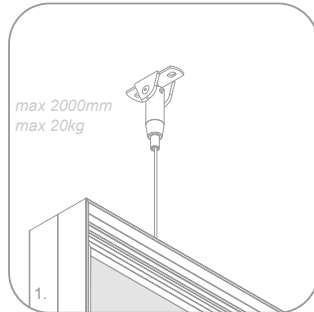

FIXING SYSTEM

Mounting example

1. Two-point cable fixation
2. Screw hook installation
3. Wall fixation using a wall bracket
4. Pre Drill installation
5. Gondola shelving
6. Portable stand

**Only to individual "Custom" series products*

**Medium size stands are up to 100 cm high and 50 cm width*

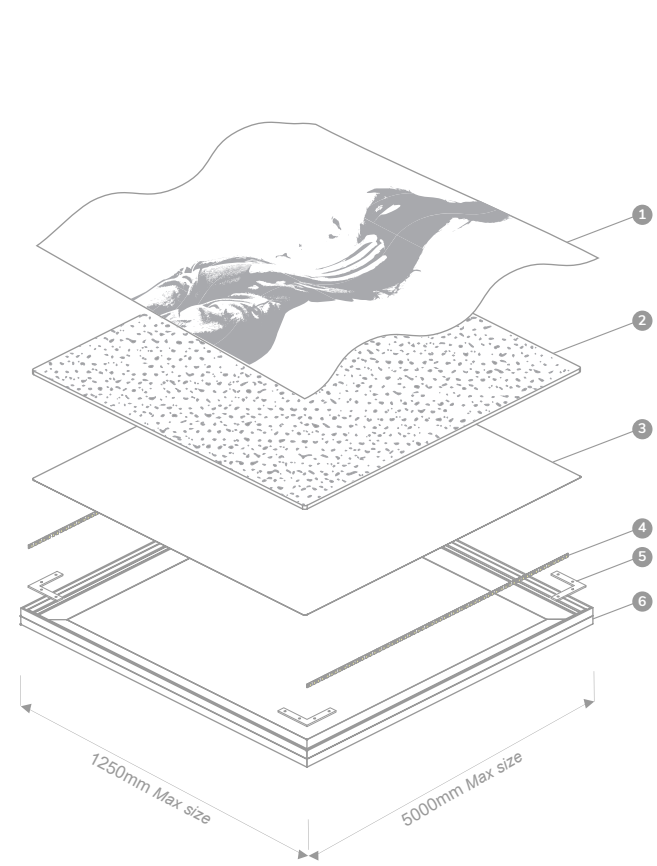

PRODUCT STRUCTURE

Technical & usage

- 1. Textile print
- 2. Acrylic sheet
- 3. Difuzer lumaire

- 4. Lumaire LED tape
- 5. Brackets
- 6. Aluminium frame

Textile Print

Final step of the light panel is to choose, design and manufacture the desirable print you want to light up. Every standard textile and rigid print works perfectly with Leddex light panels

Acrylic sheet

The most important part of the light panel. Acrylic sheet design for even light distribution on the entire surface of the product, leaving no room for hot spots or darker areas you want to light up

Reflector

A flexible material designed for supreme light reflection and color enhancement, making the most of LED lighting and acrylic sheet

LED strips

High power LED strips with integrated Intelligent Control (IC) system for ultimate reliability and maximum lighting effect.

LUMAIRE PROFILES

Lumaire Textile frame components

MAGNETIC LED PANEL - SINGLE

1. Aluminium frame
2. Lumaire LED tape
3. Acrylic sheet
4. Reflector
5. Brackets

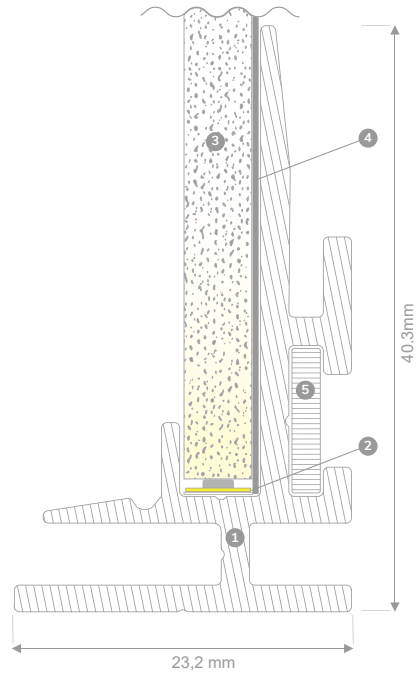

Textile Led panel - SINGLE

LUMAIRE PROFILES

Lumaire Textile frame components

MAGNETIC LED PANEL - DOUBLE

1. Aluminium frame
2. Lumaire LED tape
3. Acrylic sheet
4. Difuzer
5. Brackets

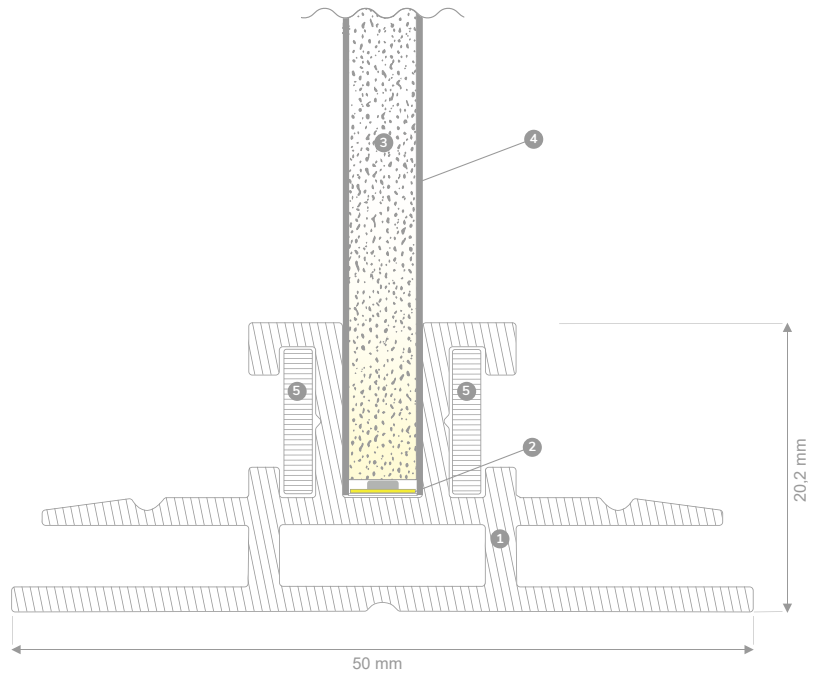

Textile Led panel - DOUBLE







LUMAIRE LED DESIGN

Lighting Projects

Lumaire Textile lights up Burberry, stores in every major city of Greece.

PRODUCT
Lumaire Textile



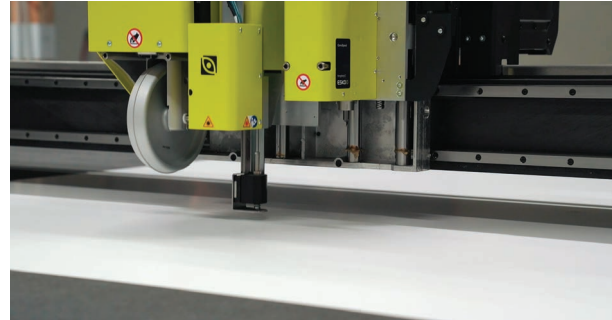
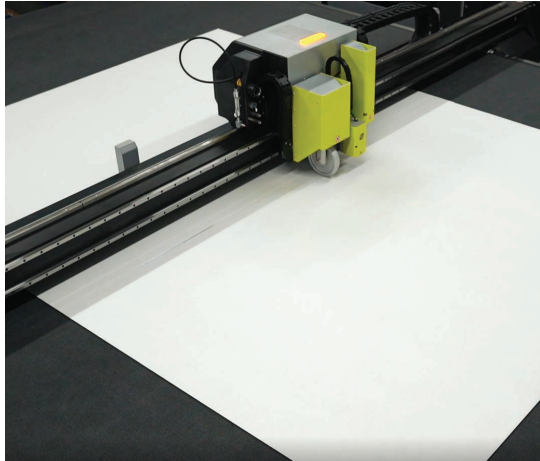

MANUFACTURE

LED light sheet | Made in Lithuania

Lumaire are the only such LED panel lighting manufacturers in Lithuania.

